

TQSB-30

MOTHER CART

Quad-Steer Designed For Precision Tracking

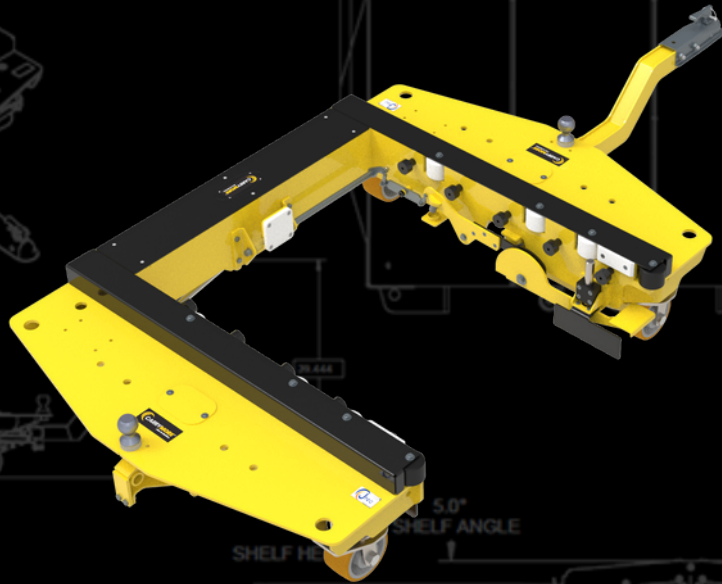

54" x 47"

Largest Recommended Cart



3,000 LBS

Weight Capacity

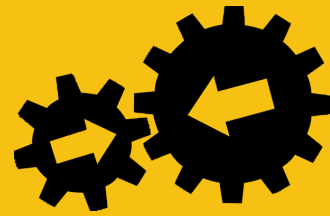

"B"

CarryMore Compatible

MODEL NUMBER	TQSB-30
TARE WEIGHT	585 lbs
CAPACITY	3,000 lbs
STEERING	Quad-Steer
ELEMATE	1.0"
MAX SLOPE	< 9%
DECK HEIGHT	15"
DECK WIDTH	47"
DECK LENGTH	54"
MAX SPEED	10 MPH
MAX SPEED IN TURN	2.5 MPH
MAX TRAIN WEIGHT	10,000 lbs

This "B" size Mother Cart, using Elemate 1.0, carries Daughter Carts up to 54" with superior tracking.

Other features include a quick-change reusable tongue allowing the cart to be pulled in either direction with a standard 2" ball coupler latching system.

Compatible Daughter Carts include:

- RBFF-3332-30
- RBFF-5050-30
- RBKC-3933-30
- RBKC-3333-30

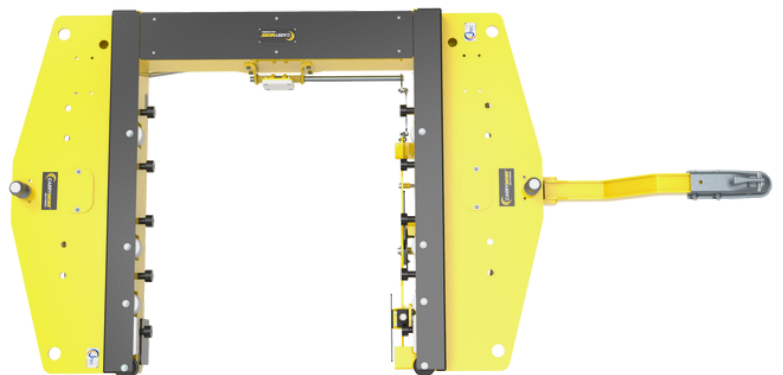

SCAN ME